

The Procurement Division of Knox County, Tennessee will receive sealed bids for the provision of **HOME REHABILITATION PROGRAM FOR CAC** as specified herein. Bids must be received by **10:00 a.m. on November 21, 2023**. Late bids will be neither considered nor returned.

**Deliver Bids to:**

**Bid Number 3486  
Knox County Procurement Division  
Suite 100, 1000 North Central Avenue  
Knoxville, Tennessee 37917**

**The Bid Envelope must show the Company Name, Bid Number, Bid Name and Bid Opening Date.**

**ADDITIONAL INFORMATION:** Knox County wants requests for additional information routed to Robert Mackey, Senior Buyer, at 865-215-5754. Questions may be emailed to [robert.mackey@knoxcounty.org](mailto:robert.mackey@knoxcounty.org).

**AWARD:** Contractor must be an approved vendor for the Home Rehabilitation Program prior to any workorders being awarded. For requirement, please use contact information listed above.

**BID DELIVERY:** Knox County requires bidders, when hand delivering bids, to time and date stamp the envelope before depositing it in the bid box. Knox County will not be responsible for any lost or misdirected mail sent by common carrier, nor will Knox County be responsible for submittals delivered to addresses or Suites other than the delivery address and Suite specified at the top of this solicitation. The time clock in the Procurement Division shall become the official record of time. Knox County shall not be responsible for technical difficulties experienced by vendors trying to register or submit their bid electronically less than twenty-four (24) hours prior to the bid opening time.

**Solicitations must be in a sealed envelope/box prior to entering the Procurement Division office. Procurement Division personnel are not allowed to see the submittal nor assist in placing documents in an envelope/box. Additionally, the Procurement Division is not responsible for providing materials (e.g. envelopes, boxes, tape) for submittals.**

**CLOSURES:** During periods of closure due to unforeseen circumstances in Knox County or closures at the direction of the Knox County Mayor, the Procurement Division will enact the following procedures in regard to solicitations and weather delays:

- If the Mayor closes the Administrative offices prior to the time set for solicitation opening of any business day, all solicitations due that same day will be moved to the next operational business day.
- Other unforeseen circumstances shall be at the sole discretion of the Procurement Director.
- Knox County shall not be liable for any commercial carrier's decision regarding deliveries during any unforeseen circumstances.

**COMPLIANCE WITH ALL LAWS:** Contractor is assumed to be familiar with and agrees to observe and comply with all federal, state, and local laws, statutes, ordinances, and regulations in any manner affecting the provision of goods and/or services, and all instructions and prohibitive orders issued regarding this work and shall obtain all necessary permits.

**INTERPRETATION:** No oral interpretation will be made to any bidder regarding the meaning of specifications or the Scope of Work. All questions are to be submitted in writing via email and will be answered in the form of an addendum to the solicitation by the Knox County Procurement Division, if applicable.

**IRAN DIVESTMENT ACT:** By submission of this bid, each bidder and each person signing on behalf of any bidder certifies, and in the case of a joint bid each party thereto certifies as to its own organization, under penalty of perjury, that to the best of its knowledge and belief that each bidder is not on the list created pursuant to Tennessee Code Annotated § 12-12-106.

**NO BOYCOTT OF ISRAEL:** Pursuant to Tennessee Code Annotated Title 12, Chapter 4, Part 1, by submission of a response to this solicitation, each bidder and each person signing on behalf of any bidder certifies, and in the case of a joint response each party thereto certifies as to its own organization, under penalty of perjury, that to the best of its knowledge and belief that each bidder is not currently engaged in, and will not for the duration of the contract engage in, a boycott of Israel.

**RIGHT TO INSPECT:** Knox County reserves the right to make periodic inspections of the manner and means the service is performed or the goods are supplied.

**VENDOR REGISTRATION:** Prior to the opening of this bid, ***ALL BIDDERS MUST*** be registered with the Procurement Division. Please register on-line at our website at [www.knoxcounty.org/procurement](http://www.knoxcounty.org/procurement) and click on "Online Vendor Registration." Vendors must be registered with the Procurement Division **prior** to submitting their bid.

These terms and conditions shall be part of the contract. Knox County reserves the right to negotiate other terms and conditions it deems appropriate and necessary under the circumstances to protect the public-trust. By submitting a bid, vendor agrees to these terms and conditions.



**WORK ORDER**  
**KNOX COUNTY HOME REHABILITATION PROGRAM**  
**BID COPY**

**WORK ORDER ID#:** 2022CN0051

**Date:** 9/13/2023

Knoxville, TN 37923

**Year Built:** 1997

**PROJECT SUPERVISOR:** Aaron Cate

**CONTRACTOR:** \_\_\_\_\_

**ALL CHANGE ORDERS MUST BE PRE APPROVED BY THE DIRECTOR HOUSING AND ENERGY SERVICES.**

**GENERAL REQUIREMENTS AND STANDARDS:**

The construction shall be accomplished without undue delay and with minimum inconvenience to the owner. All materials and products used shall be new unless otherwise specified, and applied or stalled in accordance with the manufacturer's specification and the Rehabilitation Specifications. Reference in these Specifications to any article, device, products, material, or fixture by name, make or catalogue number shall be interpreted as establishing a standard or quality. The contractor shall furnish all materials, labor, equipment, and services to perform all work in these Specifications by established building and construction practices, proceeding promptly to complete said work in the specified time so stated in the contract documents. The contractor shall obtain all necessary licenses and permits before work commences. *All work shall be carried out pursuant to the currently adopted Federal, State, City of Knoxville, and Knox County Tennessee codes and ordinances as applicable.* Mechanical, plumbing and electric contractors or subcontractors shall be licensed by the State of Tennessee. A copy of this license is to be provided to CAC. At the completion of the designated work, the contractor shall remove all temporary construction equipment, salvage materials, trash, and other debris and dispose of legally, leaving the area for which the contractor is responsible in a neat condition. Cleaning of fixtures, doors, and windows, installed under this work, shall be the responsibility of the installing Contractor.

The Contractor is required to provide the homeowner with all warranties and guarantees. This applies to everything installed on the job which carries a warranty or guaranty, i.e.; windows, faucets, etc. Failure to do so will be considered a breach of contract. Final pay request will not be approved until warranties are provided. The Contractor shall guarantee all workmanship and material for a year period from the *date* of final inspection and one year from the time of completion of any warranty work.



Work Order # 2022CN0051

Client Name: Mary Hopper

Date: 9/13/2023

**EMERGENCY REPAIR**

**Measure #2**

**Item #1 Guttering Repair/Replace:**

Install 198 linear ft of house type guttering and 4 downspouts 2 front 2 back.

**Specifications:** Install 198 linear feet oversized aluminum continuous guttering (4" x 5") and 20 linear feet oversized aluminum downspouts (3" x 4"). Install per the manufacturer's requirements and by local code office. Downspouts discharging directly onto a roof surface or into another gutter shall occur only with the prior approval of the Project Supervisor. The elbows at the discharge end of the downspout shall aim water in line with the reasonable placement of the splash blocks which are included in the gutter installation.

**Item # 2 Exterior Door Replacement(s) - Mobile Home Front Door**

Mobile Home Combo Door - Front:

**Specifications:** Install exterior door according to the manufacturers instruction and by local code office. Mobile Home Combo Front Door, size determined by contractor. Elixir Series 9000 or equal product to include trim & caulking all materials to complete measure.

**Item #3 Window Replacements(s): Dining room window**

**Specifications:** Install replacement windows (SEE DIAGRAM) according the manufacturer instruction and by local code office. Use vinyl, double-paned units with Low E glass and Argon filled. The glazing seal must have a ten year manufacturer's warranty. All windows must have a National Fenestration Rating meeting the minimum energy code requirements for North Central Zone, Energy Star Rated. Windows shall have a U-Factor equal to or less than < 0.30 and an SHGC Rating equal to or less than < 0.40.

Installation of window(s) is inclusive of all necessary wrapping exterior trim with coil stock, interior trim and casing. Finish new wood as per existing wood-work. Caulk around the entire unit with a non-hardening acrylic and latex caulk. Window style is to match existing as close as possible. All new windows to have screens. All moveable sashes are to have screens. To include trim as needed to complete measure. NOTE: It is the contractor's responsibility to verify all measurements before ordering windows and to verify any code requirements for the project. Must follow RRP Rules if home is pre-1978. Must leave stickers on windows till CAC Post Inspection has passed.

ITEM	L	M	DESCRIPTION	UNITS	AMT.	UNIT COST	TOTAL
1	X		Labor	LF	198		
1		X	Materials	LF	198		
2	X		Labor	EA	1		
2		X	Materials	EA	1		
3	X		Labor	EA	1		
3		X	Materials	EA	1		
					<b>MEASURE 2 TOTAL</b>		











MARRY HOOPER

2022CN0051

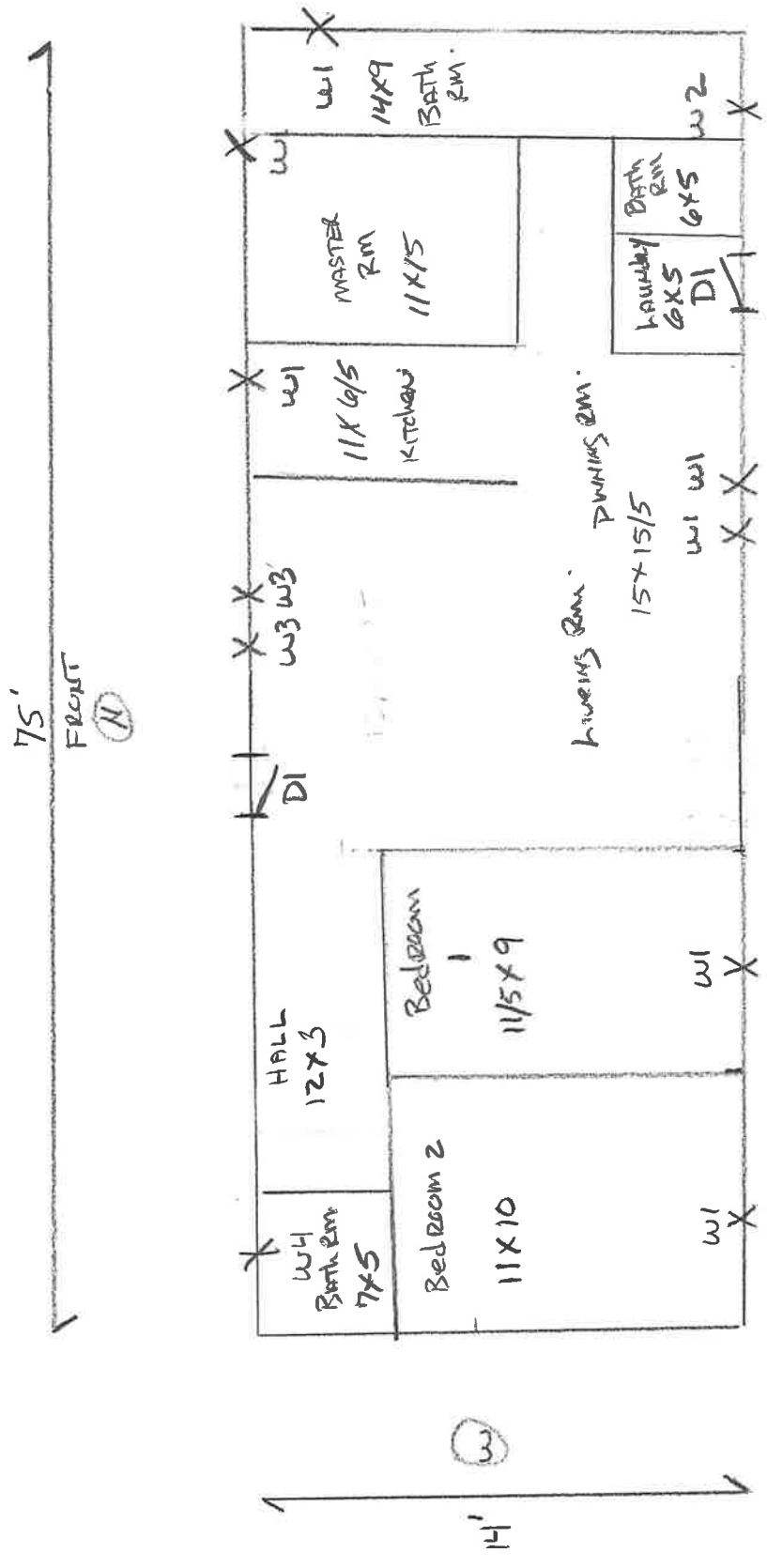

Window: Door:

W1 30x55 DI 32x79

W2 14x22

W3 30x60

W4 14x40

NAILING DOWN  
ALL SIDES

2"x2" Spindles

2"x4" Railings

1/4" PLY

5/4  
STEP TREADS  
3' WIDE

3 - 2"x12" STRINGERS

5/4 TOP PLATES

2"x2" Spindles

2"x4" Railings

2"x8" BAND

2"x8" JOIST

5/4 DECKING

4"x4" SUPPORT POST

< 4' TO GRADE

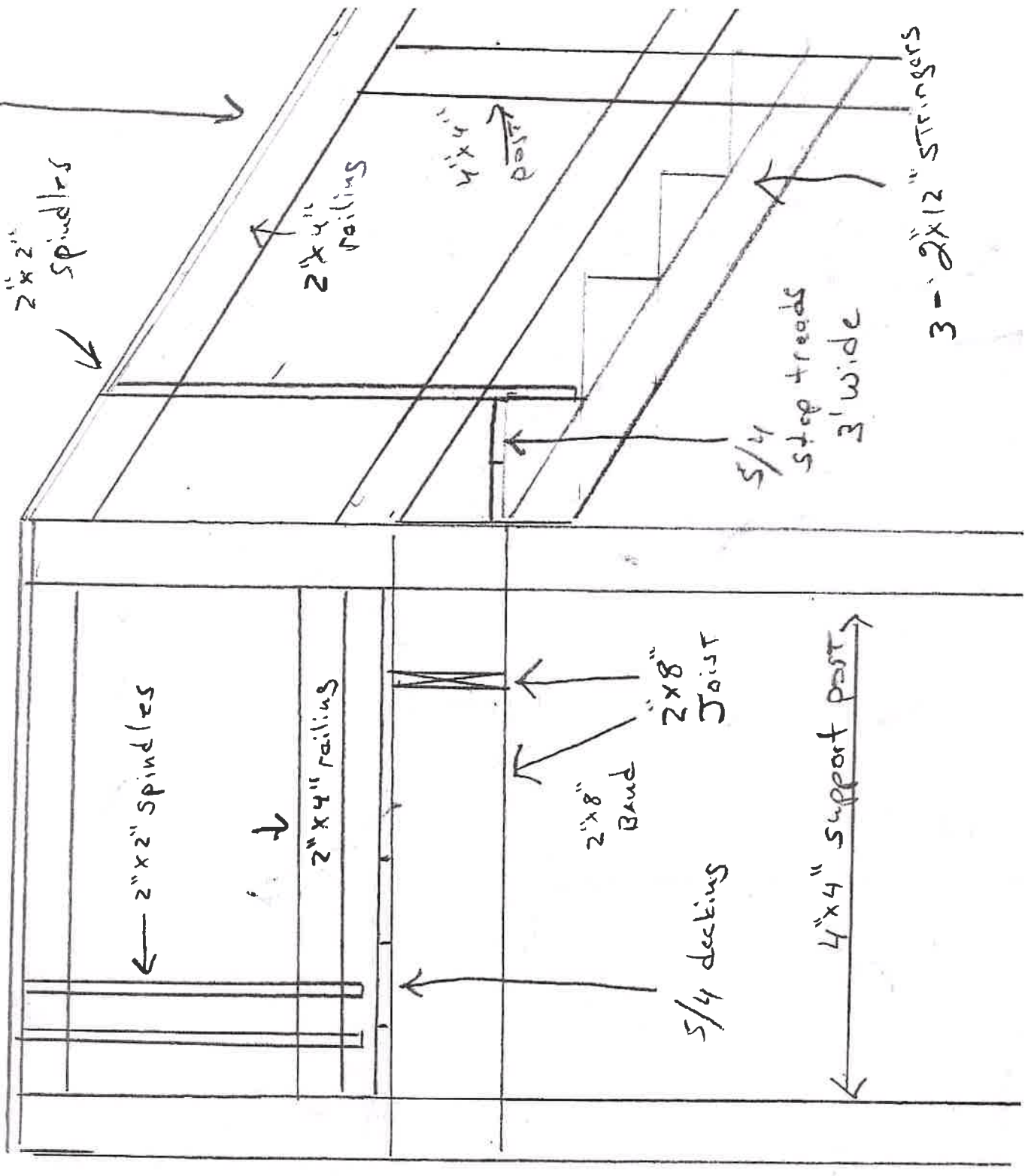

# Knox County Code Administration & Inspection

## Residential Deck Code Handout

REV. 060821



**This handout is a guide and is not all-inclusive and all materials must be installed per the manufacturers' instructions and the 2018 International Residential Code IRC.**

1. Z-Flashing shall be installed at top of the ledger board and regular flat flashing between the ledger board and the house wall. Flashing shall be continuous corrosion resistance type and installed per manufacturers' instructions. This is usually stainless, double hot dipped galvanized, vinyl or copper. Aluminum flashing is not allowed due to the corrosive nature of the treated lumber.
2. The house wall ledger board shall be bolted to the house and be the same size as the floor joists or larger.
3. The house ledger board shall be bolted (staggered top to bottom) to the house with 1/2" dia. lag bolts \* or through-bolted with washers that are long enough to fully penetrate the structural member of the house. Bolt spacing shall be as follows:
 

Joist Span	6' and less	Bolt Spacing	30" oc
Joist Span	6'1" to 8'	Bolt Spacing	23" oc
Joist Span	8'1" to 10'	Bolt Spacing	18" oc
Joist Span	10'1" to 12'	Bolt Spacing	15" oc
Joist Span	12'1" to 14'	Bolt Spacing	13" oc
Joist Span	14'1" to 16'	Bolt Spacing	11" oc
Joist Span	16'1" to 18'	Bolt Spacing	10" oc
4. **Do not bolt to brick.** Center of bolts must be at least 2" from the edge. Joist hangers shall be sized and anchored \* in accordance to the joist size and manufacturer's instructions.
5. Joists shall be sized per **table 1**.
6. Joists are permitted to cantilever 1/4 of the joist span or the maximum cantilever length specified in **table 1**, whichever is less.
7. Deck beams shall be sized and supported in accordance with **table 4**. Beams must be fully supported by and structurally anchored to posts. Beam plies shall be fastened with two rows of 3" 10d nails minimum 16" on center along each edge.
8. Deck beams are permitted to cantilever at each end up to 1/4 of the allowable beam span.
9. Posts shall be sized in accordance with **table 2**. All posts must be structurally anchored to the footing.
10. Footings shall be sized in accordance with **table 3**.

**\* ALL FASTENERS, HANGERS, AND NAILS ARE TO BE DOUBLE HOT DIPPED GALVANIZED OR STAINLESS STEEL.**

### Guardrails:

Porches and decks with a raised floor surface located more than 30" above the grade or floor below shall have guardrails not less than 36" in height. Intermediate rails shall be placed which do not allow passage of a 4" sphere.

### Stairs and Handrails:

Open sides of stairs with a total rise of more than 30" above the grade or floor below shall have guardrails not less than 34" in height measured vertically from the nosing of the treads. Intermediate rails shall be placed which do not allow passage of a 4" sphere. Handrails shall be provided on at least one side for stairs with 4 or more risers. Handrails shall be continuous, graspable, and terminate into posts or returns in accordance with R311.7.8. Landings shall be provided at the top and bottom of stairs with a minimum size of the width of the stairs x 36" in the direction of travel. R311.7.6

### Treads and Risers:

The maximum riser height shall be 7-3/4" (measured vertically between leading edges of adjacent treads). The minimum tread depth shall be 10". A nosing not less than 3/4", but not more than 1-1/2" shall be provided on stairs with treads less than 11". Risers for stairs greater than 30" above grade shall not have openings of more than 4".

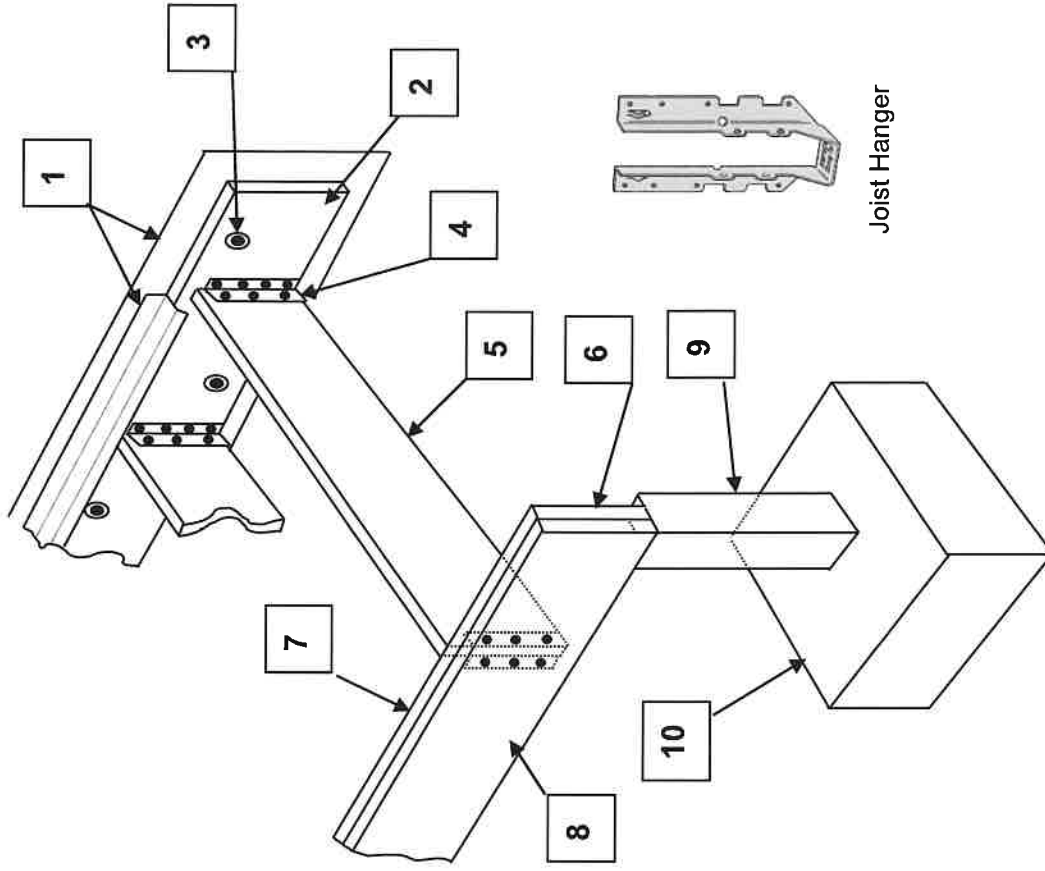

Based on the 2018 International Residential Code. Other materials, configurations, or engineered designs may be utilized that fall within the guidelines of this code.

**TABLE 1**

Joist Size	DECK JOIST SPANS				MAXIMUM CANTILEVER			
	12" oc	16" oc	24" oc	12" oc	16" oc	24" oc	16" oc	24" oc
2" x 6"	9'-11"	9'-0"	7'-7"	1'-3"	1'-4"	1'-6"	1'-4"	1'-6"
2" x 8"	13'-1"	11'-10"	9'-8"	2'-1"	2'-3"	2'-5"	2'-3"	2'-5"
2" x 10"	16'-2"	14'-0"	11'-5"	3'-4"	3'-6"	2'-10"	3'-6"	2'-10"
2" x 12"	18'-0"	16'-6"	13'-6"	4'-6"	4'-2"	3'-4"	4'-2"	3'-4"

**TABLE 2**

Post Height	Wood Post Size
0' to 6'-9"	4" x 4"
8'	4" x 6"
14'-0"	6" x 6"
14'-0"	8" x 8"

Note: Height measured to the underside of the beam

**TABLE 3: Deck Pier Footing Chart**

Beam Size	2 @ 2"x6" or a single member	2 @ 2"x8"	2 @ 2"x10"	2 @ 2"x12"
Square Footing Size	12" x 12"	17" x 17"	20" x 20"	24" x 24"
Round Footing Size	14"	19"	23"	27"

Note: Minimum thickness of concrete = 6", minimum footing depth = 12". Install two (2) #4 rebar in each direction spaced 6" on center.  
Based on highest load case. See Table R507.3.1 for minimum allowable sizes.

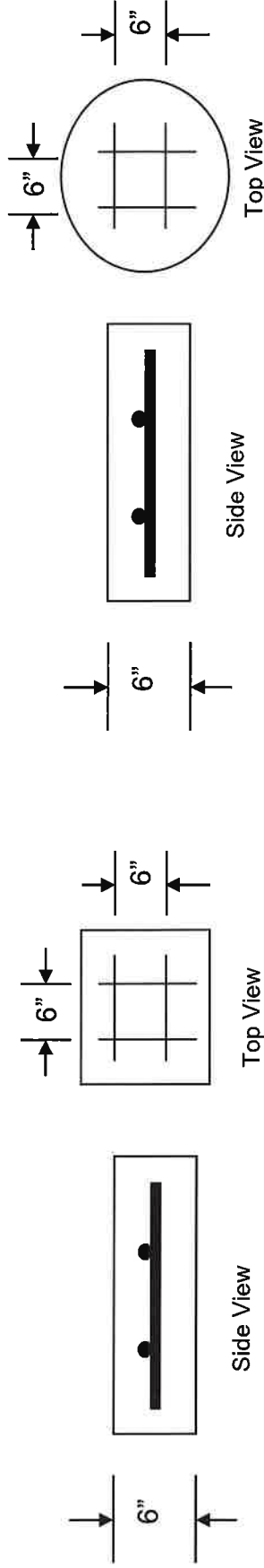

**Typical Square Footing Rebar Placement**

**Typical Round Footing Rebar Placement**

**TABLE 4: DECK BEAM SPAN LENGTHS**

WOOD SPECIES	SIZE	DECK JOIST SPAN LESS THAN OR EQUAL TO:						
		6'	8'	10'	12'	14'	16'	18'
Southern Pine	(1) 2 x 6	4' - 11"	4' - 0"	3' - 7"	3' - 3"	3' - 0"	2' - 10"	2' - 8"
	(1) 2 x 8	5' - 11"	5' - 1"	4' - 7"	4' - 2"	2' - 10"	3' - 7"	3' - 5"
	(1) 2 x 10	7' - 0"	6' - 0"	5' - 5"	4' - 11"	4' - 7"	4' - 3"	4' - 0"
	(1) 2 x 12	8' - 3"	7' - 1"	6' - 4"	5' - 10"	5' - 5"	5' - 0"	4' - 9"
	(2) 2 x 6	6' - 11"	5' - 11"	5' - 4"	4' - 10"	4' - 6"	4' - 3"	4' - 0"
	(2) 2 x 8	8' - 9"	7' - 7"	6' - 9"	6' - 2"	5' - 9"	5' - 4"	5' - 0"
	(2) 2 x 10	10' - 4"	9' - 0"	8' - 0"	7' - 4"	6' - 9"	6' - 4"	6' - 0"
	(2) 2 x 12	12' - 2"	10' - 7"	9' - 5"	8' - 7"	8' - 0"	7' - 6"	7' - 0"
	(3) 2 x 6	8' - 2"	7' - 5"	6' - 8"	6' - 1"	5' - 8"	5' - 3"	5' - 0"
	(3) 2 x 8	10' - 10"	9' - 6"	8' - 6"	7' - 9"	7' - 2"	6' - 8"	6' - 4"
	(3) 2 x 10	13' - 0"	11' - 3"	10' - 0"	9' - 2"	8' - 6"	7' - 11"	7' - 6"
	(3) 2 x 12	15' - 3"	13' - 3"	11' - 10"	10' - 9"	10' - 0"	9' - 4"	8' - 10"

Southern Pine lumber sizes for No. 2 grade are shown in regular type, with number of plies given in parentheses. Southern Pine glued laminated timber beams should be used when (3) 2x12's no longer meet design conditions. The ends of beams are required to have not less than 1.5" of bearing on wood or metal and not less than 3" of bearing on concrete or masonry for the entire width of the beam. Where multiple-span beams bear on intermediate posts, each ply must have full bearing on the post.

**Steps in Using this Table:**

1. Find the span of the deck joists.
2. Find the span of the deck beam required.
3. Select the number of plies and size of the Southern Pine timber.
4. Beams supporting face mounted joists cannot be smaller than joist. Joist hangers are required.
5. Beams shall be supported to foundations

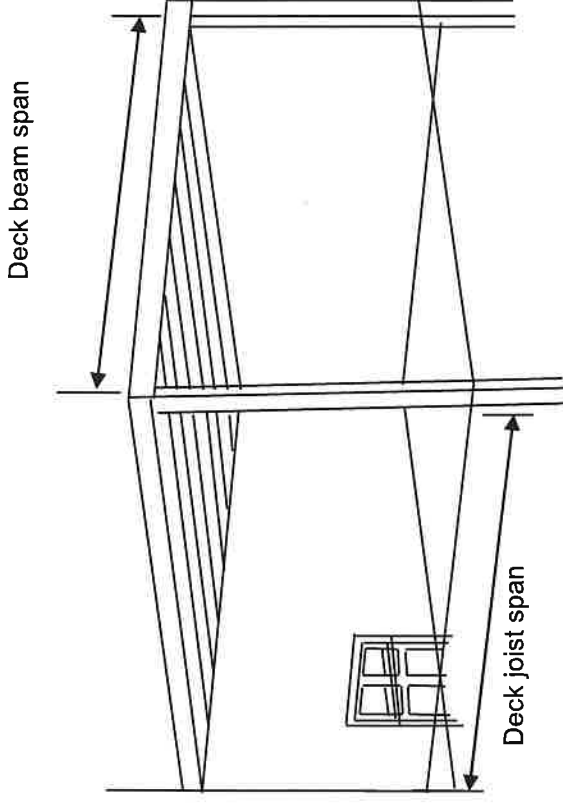

## LATERAL BRACING

Member sizes were designed assuming beams were braced continuously to prevent lateral compression buckling. Where the lateral load connection is provided as shown in Figure 1 below, hold-down tension devices shall be installed in not less than two locations per deck, within 24" of each end of the deck. Where the lateral load connection is provided as shown in Figure 2, the hold-down tension devices shall be installed in not less than four locations per deck.

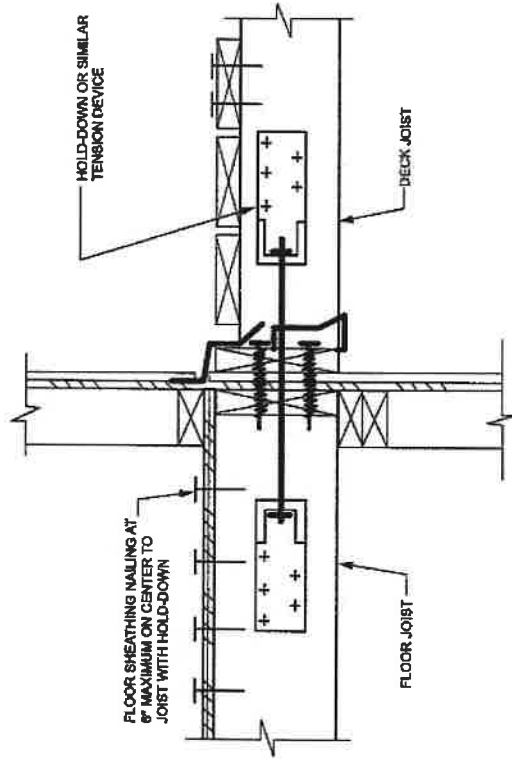

FIGURE 1

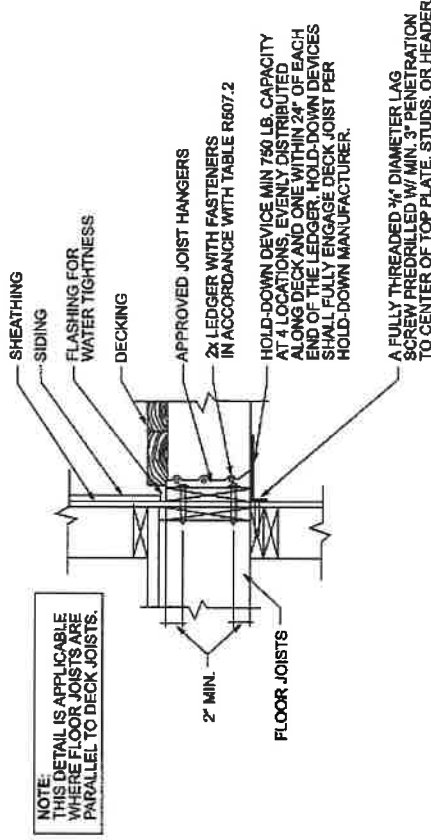

FIGURE 2

## DECK ATTACHMENT FOR LATERAL LOADS

EXAMPLE 1A:



**EXAMPLE 1B:** A second method of construction is to have the deck boards running perpendicular to the house with floor joists running parallel. This method uses a deck beam loaded on both sides to allow joist spans of 7'-6". Using **Table 1** and a joist spacing of 24" on center, 2x6 joists can be used. The house wall ledger board in this case is not required since ledger boards are not allowed to support concentrated loads from beams or girders. Additional posts will be required at the house to support the deck beams. The deck beams will now run perpendicular to the house and the deck is free-standing. **Table 4** shows us that 2-2x8 deck beams will span 7'-7" between posts. This means that for a 12' deck beam a post will be required mid-span of the beam and another at each end of the beam. Again, **Table 2** requires 6" x 6" posts for a deck height of 10' and **Table 3** shows footings of 17" x 17" square or 19" diameter round when using 2-2x8 beams or girders. Lateral load tension devices will be installed per Figure 1 or Figure 2 above.

**Note: The house rim / band board must be structurally attached to the house frame.**

